



## **BLADE**

A BOLD AND STRIKING PRESENCE,  
BLADE PUSHES THE BOUNDARIES OF  
WHAT IS POSSIBLE WITH SOUND. THE WORLD'S  
SINGLE APPARENT SOURCE LOUDSPEAKER

**NOW WITH KEF'S INNOVATIVE  
METAMATERIAL ABSORPTION TECHNOLOGY.**

# A SOUND STATEMENT

AN ICON THAT ENGAGES EVERY SENSE



## UNCOMPROMISED INNOVATION

Blade is an attitude. It's about exploring the art of the possible, without preconceptions.

Obsessed with sound quality and committed to bringing a superior listening experience, KEF has been pioneering innovative acoustic engineering since 1961. In 2009 we gave our engineers free rein to create a speaker to showcase KEF's technology leadership and powers of innovation with no preconceptions and restrictions, they came up with the revolutionary Concept Blade – the world's first Single Apparent Source loudspeaker.



Concept Blade realised in 2009



Blade realised in 2011 and  
Blade Two realised in 2014

## FROM CONCEPT TO REAL ENJOYMENT

The concept was further refined and developed for production in 2011, when Blade became HiFi loudspeakers that serious audiophiles could actually own. Like the original Blade, a smaller model Blade Two was introduced in 2014 with the same advanced materials and technologies.

Blade is about exploring the art of the possible and pushing boundaries of HiFi sound without preconceptions which is why the latest version of Blade benefits from our latest acoustic innovations: Metamaterial Absorption Technology (MAT™), a bespoke 12<sup>th</sup> generation Uni-Q driver array and a host of other improvements.

The latest Blade consists of two models: Blade One Meta and Blade Two Meta. Both sharing the same DNA, the same technology and the same striking aesthetic, Blade Two Meta is on a slightly smaller scale.

Whichever model you choose, it's a spectacularly warm and expansive sound, wherever you sit. Seamless and natural, effortlessly accurate in every detail, and as emotionally true as a live performance.



Blade One Meta and Blade Two Meta

## REDEFINING THE POSSIBLE

Blade set out to extend the boundaries of what high-end audio can achieve.

Its exceptional acoustic integrity derives from the combination of carefully chosen components, new high performance drivers designed to behave with no break-up or resonance over their required frequency range and an inert, radically shaped cabinet engineered every to interfere with the uncompromised purity of their output.

You will hear that familiar tracks sound noticeably sweeter and more involving as a result, or that the bass sounds fuller, cleaner and better controlled.





REAL. COHERENT. IMMERSIVE.

Single Apparent Source technology delivers sound from one point in space over the entire spectrum. Single source. Coherent sound.

At the heart of Blade lies Single Apparent Source technology. It is an extension to the iconic Uni-Q driver array, the building block of KEF signature sound. Single Apparent Source technology aims to achieve the acoustic ideal of a point source, where low, mid and high frequencies radiate from one point. Four low-frequency drivers in symmetrically opposing pairs are tightly packed around a two-way Uni-Q driver where the mid-frequency and high-frequency share the same acoustic centre. The result is noticeably more precise imaging and highly accurate sound across a wider area.

Blade is the world's first Single Apparent Source loudspeaker that extended the boundaries of what high-end audio can achieve. It is what makes the Blade incredibly coherent across the frequency range, with noticeably more precise imaging that is possible from any conventional speaker.

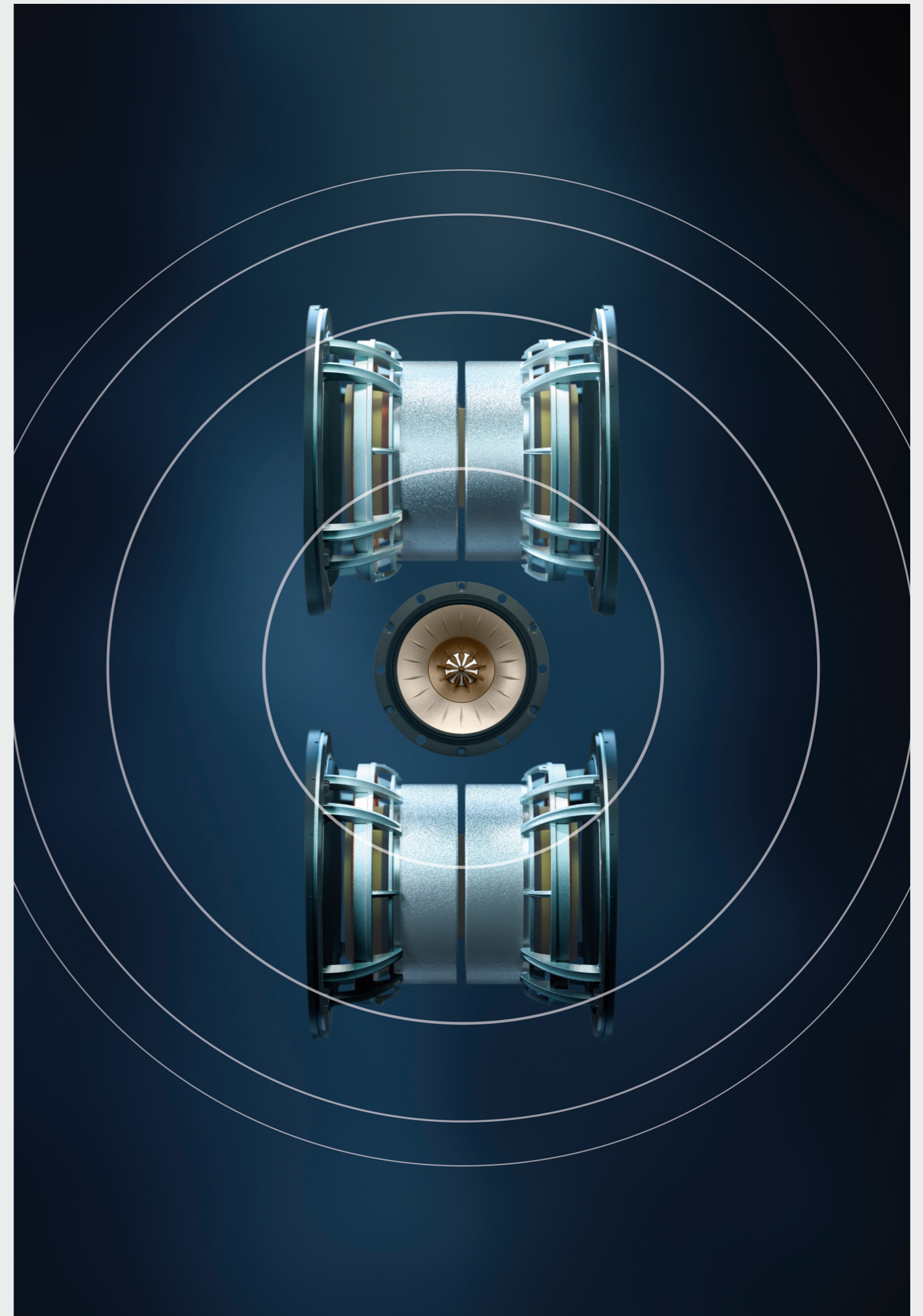

## REVOLUTIONARY SOUND ABSORPTION WITH MAT™

A truly revolutionary tool in the KEF acoustic armoury, MAT™ breaks completely new ground in speaker design.

Metamaterial Absorption Technology (MAT) is a highly complex maze-like structure, where each of the intricate channels efficiently absorbs a specific frequency. When combined, the channels act as an acoustic black hole, absorbing 99% of the unwanted sound that comes from the rear of the tweeter, eliminating the resulting distortion and providing a purer, more natural acoustic performance.

Metamaterials are specially developed structures that use existing materials in such a way that they exhibit new, desirable properties that are simply not found in naturally occurring substances.

A result of joint development with the Acoustic Metamaterials Group, using MAT breaks completely new ground in loudspeaker design, and once again demonstrates KEF's unrelenting passion for developing new technologies to improve your listening experience.



"A clever way of absorbing unwanted sound waves."

- What Hi-Fi? Innovation of the Year 2020







## A RELENTLESS PASSION FOR EXCELLENCE

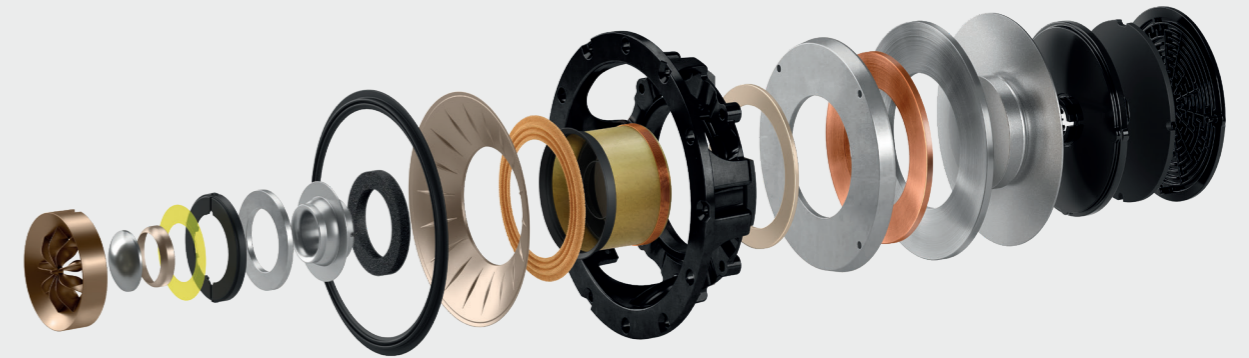

KEF has always been obsessed with perfecting the reproduction of recorded sound, with a continuous stream of technical innovations that have shaped the evolution of loudspeaker design.

KEF was the first to apply computer analysis to optimising sonic performance, using aerospace-derived modelling techniques such as finite element analysis. We pioneered driver decoupling, pair matching, coupled cavity bass loading, conjugate load matching, and acoustic compliance enhancement. Out of all the pioneering developments and technological breakthroughs, it is the Uni-Q® driver array that sits at the heart of almost all our speakers. It is the building block of KEF signature sound. Uni-Q's outstanding clarity and

exceptionally broad dispersion characteristics deliver immaculately defined sonic imagery over a listening area far larger than is possible with any conventional speaker.

## SIT ANYWHERE, HEAR EVERY DETAIL

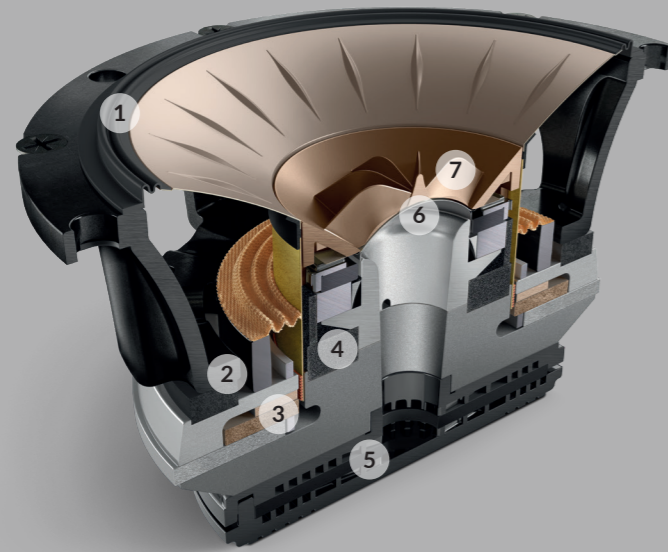

Uni-Q technology places the tweeter precisely at the acoustic centre of the bass/midrange cone, so both act together as a single point source to disperse sound more evenly throughout the room. The result is the elimination of the limited 'sweet spot', therefore allowing everybody sitting at different spots in the room to experience and enjoy the same natural, detailed sound.

Refined through iterations, the latest Uni-Q driver array for Blade is the 12<sup>th</sup> generation Uni-Q with MAT™. A bespoke driver array engineered to deliver pristine performance, it is the result of decades of accumulated in-house knowledge and the application of cutting-edge simulation and analysis tools.

### 1 Driver surround

A new driver surround is designed to allow longer excursion without causing diffraction and extending the frequency range of the mid-frequency. Plus, the contours of the dome, midrange horn and surround are all computer-optimised to ensure a perfectly smooth transition to the cabinet.

### 2 Flexible decoupling chassis

A new flexible decoupling chassis is designed to reduce vibration and reduce coloration. It ensures that any vibrations generated by the mid and high-frequency motor system are not transmitted to the loudspeaker cabinet.

### 3 Ultra-low distortion MF motor

A new ultra-low distortion

midrange motor design uses a copper ring embedded into the motor gap to minimise inductance and variation of inductance with coil position. This lowers the midrange THD and reduces thermal compression, leading to improved efficiency.

### 4 Tweeter gap damper

The tweeter gap damper is re-engineered to maximise the space at the back of the tweeter for the new metamaterial absorber.

### 5 MAT tweeter absorber

The MAT tweeter absorber is a highly complex maze-like structure, where each of the intricate channels efficiently absorbs a specific frequency.

## POWERFUL, ARTICULATE BASS

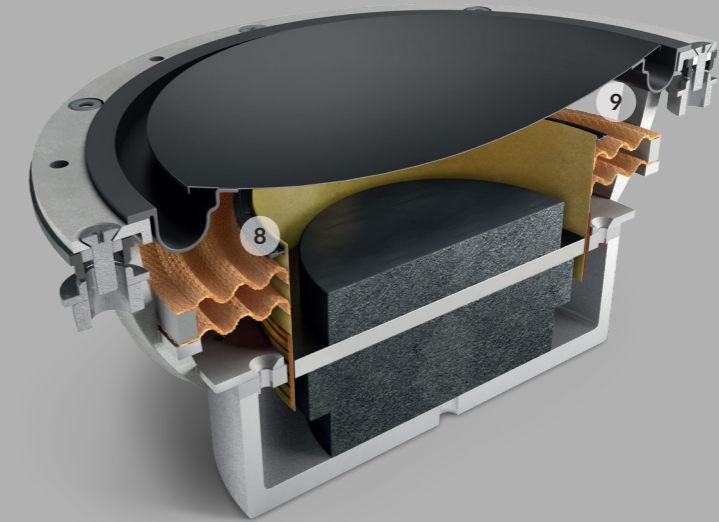

When combined, the channels absorb 99% of the unwanted sound from the rear of the tweeter.

### 6 Tweeter dome

The new stiffened aluminium tweeter dome that sits at the centre of the state-of-the-art Uni-Q driver array is capable of delivering consistently sweet, lucid and lyrical treble, irrespective of the volume.

### 7 Tangerine waveguide

The patented tangerine waveguide technology manages the airflow to recreate the wide, even spread of a natural sound field, dispersing the astonishingly pure high-frequency imaging throughout the room.

Blade's four vented low frequency drivers deliver powerful, articulate bass.

Perfectly integrated with the 12<sup>th</sup> generation Uni-Q with MAT, the four bass drivers of Blade provide exceptionally deep, clean and authoritative bass response. In line with the purity of the original Blade concept, decoupling the voice coil from the diaphragm allows low order crossovers to be used, for purer, silkier bass response.

### 8 Decoupled diaphragm

Instead of using high order crossovers to prevent the LF cone from reaching its break-up frequency, decoupling the voice coil from the diaphragm allows Blade to benefit from the acoustic advantages of low order crossovers: purer sound and silkier bass response, irrespective of volume.

### 9 Vented coupler

Distortion effects caused by trapped turbulent air have been engineered out by venting the spacer above the voice coil to allow the air to escape freely, however hard they are driven. LF performance therefore remains lucid, clean and involving when playing loud.

## POWER IN CONTROL

Blade's four powerful low frequency drivers are mounted back-to-back to cancel out kinetic forces that might otherwise colour their output.

By minimising cabinet coloration, this highly effective force-cancelling configuration partly accounts for the astonishing low-level resonance and the natural-sounding and engagingly musical performance.



Conventional speaker  
generating cabinet resonance

Blade with force-cancelling drivers  
to minimise resonance

## CUTTING EDGE SOUND

Nothing has been overlooked in the quest for clarity, right across the frequency range.

In the latest Blade, the crossover design has been enhanced to fine-tune the signal path for maximum clarity.

Each pair of low frequency drivers is located in its own chamber. This approach reduces the potential for interference between the driver units, while also reducing the need for damping which can impair bass quality.

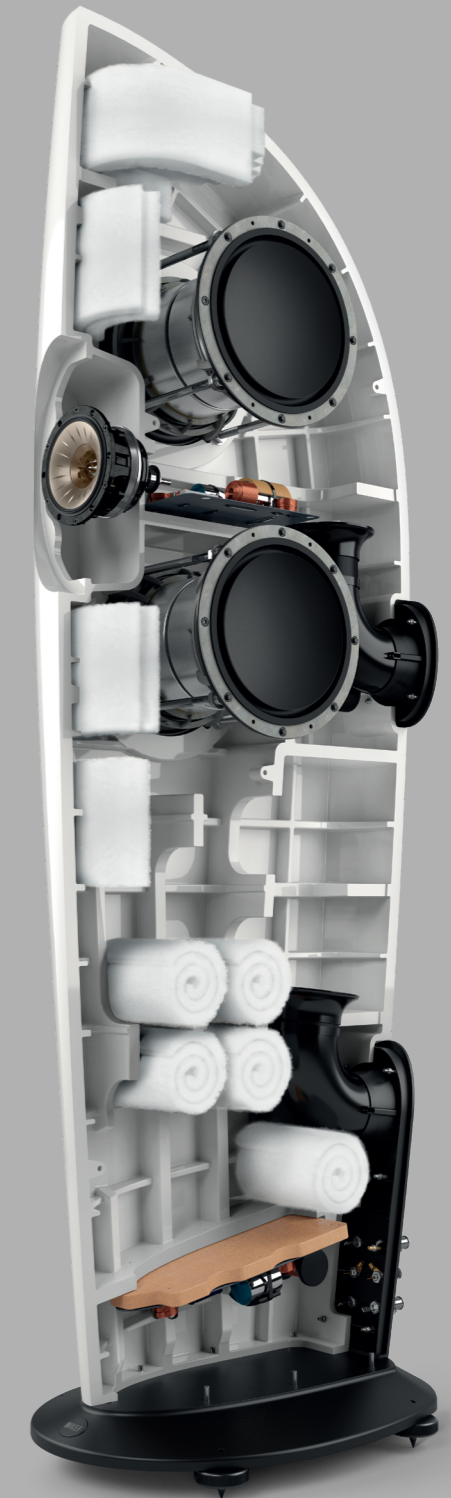

## PERFORMANCE BY DESIGN

With the philosophy of innovating in pursuit of the most accurate and realistic sound, Blade is about perfecting a groundbreaking concept to delight people with the ultimate listening experience. Blade's sculptural design is dictated by acoustics. Tapering gracefully from top to bottom and from front to rear, the gentle front radius presents no discontinuity to mar sound clarity. Made from an ultra-high density polyurethane composite, the acoustically inert cabinets' complex parabolic curves are cleverly engineered to eliminate standing waves that might blur the sound.

The KEF team initially worked alongside Eric Chan of New York-based design firm ECCO Design to create a distinctive visual identity to match Blade's towering performance.

The challenge was to design an acoustically efficient enclosure for a sizeable speaker whose driver configuration demanded large capacity at the upper portion, without looking at all bulky.

As functional as they are beautiful, the resulting cabinets are like works of art where the form was inspired by the great sculptor Brancusi's modernist masterpiece 'Bird in Space'.

Tapering gracefully from top to bottom and from front to rear, the slim proportions made possible by the single apparent source configuration give Blade a sculptural presence in its own right.





# SPECIFICATIONS



Model	<b>BLADE ONE Meta</b>
Design	Three-way bass reflex Single apparent source
Drive units	Uni-Q driver array: HF: 25 mm (1 in.) aluminium dome with MAT MF: 125 mm (5 in.) aluminium cone Bass units: LF: 4 x 225 mm (9 in.) aluminium cone, force cancelling
Frequency range free field (-6dB)	27 Hz - 45k Hz
Frequency range typical in room bass response (-6dB)	20Hz
Frequency response (±3dB)	35 Hz - 35k Hz
Crossover frequencies	350 Hz, 2k Hz
Amplifier requirements	50 - 400W
Sensitivity (2.83V/1m)	88 dB
Harmonic distortion 2 <sup>nd</sup> and 3 <sup>rd</sup> harmonics (90dB, 1m)	<0.5% 40 Hz - 100k Hz <0.2% 200 Hz - 2k Hz <0.1% 2k Hz - 20k Hz
Maximum output (SPL) (peak sound pressure level at 1m with pink noise)	117dB
Impedance	4 Ω (min. 2.8 Ω)
Weight	57.2 kg (126 lbs.)
Dimensions - with plinth (H x W x D)	1590 x 363 x 540 mm (62.5 x 14.3 x 21.2 in.)
Standard finishes	Piano Black/Copper, Piano Black/Grey, Frosted Blue/Blue, Frosted Blue/Bronze, Charcoal Grey/Red, Charcoal Grey/Bronze, Racing Red/Grey, Arctic White/Champagne



Model	<b>BLADE TWO Meta</b>
Design	Three-way bass reflex Single apparent source
Drive units	Uni-Q driver array: HF: 25 mm (1 in.) aluminium dome with MAT MF: 125 mm (5 in.) aluminium cone Bass units: LF: 4 x 165 mm (6.5 in.) aluminium cone, force cancelling
Frequency range free field (-6dB)	30 Hz - 45k Hz
Frequency range typical in room bass response (-6dB)	25Hz
Frequency response (±3dB)	33 Hz - 35k Hz
Crossover frequencies	450 Hz, 2.2k Hz
Amplifier requirements	50 - 400W
Sensitivity (2.83V/1m)	86 dB
Harmonic distortion 2 <sup>nd</sup> and 3 <sup>rd</sup> harmonics (90dB, 1m)	<0.5% 40 Hz - 100k Hz <0.2% 200 Hz - 2k Hz <0.1% 2k Hz - 20k Hz
Maximum output (SPL) (peak sound pressure level at 1m with pink noise)	116dB
Impedance	4 Ω (min. 3.2 Ω)
Weight	35.3kg (77.8 lbs.)
Dimensions - with plinth (H x W x D)	1461 x 338 x 475 mm (57.5 x 13.3 x 18.7 in.)
Standard finishes	Piano Black/Copper, Piano Black/Grey, Frosted Blue/Blue, Frosted Blue/Bronze, Charcoal Grey/Red, Charcoal Grey/Bronze, Racing Red/Grey, Arctic White/Champagne

KEF reserves the right, in line with continuing research and development, to amend or change specifications. E&OE

## FINISHES



Asserting the sophistication of the technology they contain, the Blade speakers are available in a palette of eight finishes as standard, created by blending five cabinet finishes with six Uni-Q driver cone colours: Piano Black/Copper, Piano Black/Grey, Frosted Blue/Blue, Frosted Blue/Bronze, Charcoal Grey/Red, Charcoal Grey/Bronze, Racing Red/Grey, and Arctic White/Champagne. Out of the five cabinet finishes, the Piano Black, Racing Red and Arctic White are glossy finishes while the Frosted Blue and Charcoal Grey are matte finishes.



Piano Black/Copper



Piano Black/Grey



Frosted Blue/Blue

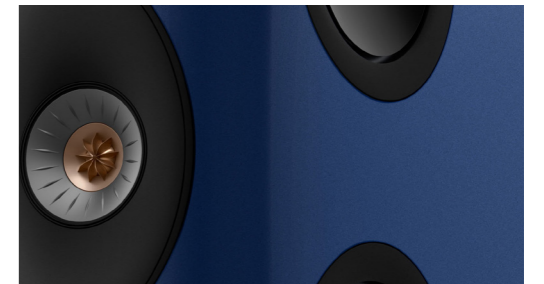

Frosted Blue/Bronze



Charcoal Grey/Red



Charcoal Grey/Bronze



Racing Red/Grey



Arctic White/Champagne

## LIMITLESS CHOICE

Looking for the perfect colour match for your listening room?

Upon request, we can match any colour you specify for the Blade speaker cabinet whether you want to make a distinctive statement or the perfect colour match for your listening room. You can simply create your own customised colour scheme by supplying a pantone of your choice for the speaker enclosure to match with any of the six standard Uni-Q driver cone colours: copper, grey, bronze, blue, red and champagne. Like everything else about Blade, it is about getting every last detail absolutely right.





# EXPERIENCE BLADE

The proof is in the listening.  
Hearing Blade in all its glory is the  
only way to appreciate exactly what  
this loudspeaker is capable of.

Find a retailer



