



# Table of Contents

<b>Introduction</b>	<b>3</b>
<b>Important Notes on Servicing</b>	<b>3</b>
<b>Ordering Replacement Parts</b>	<b>3</b>
<b>Block Diagrams</b>	<b>4</b>
<b>Start up Procedure</b>	<b>5</b>
<b>Protection Modes and Indicators</b>	<b>6</b>
<b>Troubleshooting Guide</b>	<b>7</b>
<b>Output Transistors Testing and Replacement</b>	<b>8</b>
<b>Calibrations and Adjustments</b>	<b>9</b>
<b>Parts List</b>	<b>10</b>
<b>Updates</b>	<b>11</b>
<b>Fuses</b>	<b>12</b>
<b>Voltage Change</b>	<b>12</b>
<b>IR Interface Information</b>	<b>13</b>
<b>Schematics</b>	<b>14</b>

The contents of this document as well as the files associated with it contain confidential information that is proprietary to Classé Audio Incorporated and are intended solely for the purpose of servicing product. No part of its contents may be used, copied, disclosed, or conveyed to any party in any manner whatsoever without prior written permission from Classé Audio Incorporated.

# Introduction

Please read this manual carefully before commencing servicing!  
Only qualified and authorized personnel should attempt to service this product.



The lightning flash with arrowhead symbol, within an equilateral triangle, is intended to alert the user to the presence of uninsulated dangerous voltage within the product's enclosure that may be of sufficient magnitude to constitute a risk of electric shock to persons.



The exclamation point within an equilateral triangle is intended to alert the user to the presence of important operating and maintenance (servicing) instructions.

Classé has a global product support network. For product assistance or to order replacement parts please contact your nearest service center always quoting the unit serial number.

## North America

Phone: (978) 664-2870 E-mail: [classe@bwgroupusa.com](mailto:classe@bwgroupusa.com)

## Europe

Phone: 44 (0) 1903 221 700 E-mail: [classe@bwgroup.com](mailto:classe@bwgroup.com)

## Asia

Phone: (852) 2790 8903 E-mail: [classe@bwgroup.hk](mailto:classe@bwgroup.hk)

## Rest of the World

Phone: (514) 636-6384 E-mail: [cservice@classeaudio.com](mailto:cservice@classeaudio.com)

## Important Notes on Servicing

1. ALWAYS observe ESD precautions when handling electronic modules or PCBAs.
2. NEVER exchange boards with a different revision number, unless authorized by Classé.
3. ALWAYS use Classé original replacement parts. The use of generic parts may void the warranty of the unit.

## Ordering Replacement Parts

There may be a delay in processing incomplete requests. Please be sure to include all required information. Remember to quote the serial number of the unit on all replacement part orders and the Classé order number when returning defective parts for credit.

# Block diagrams

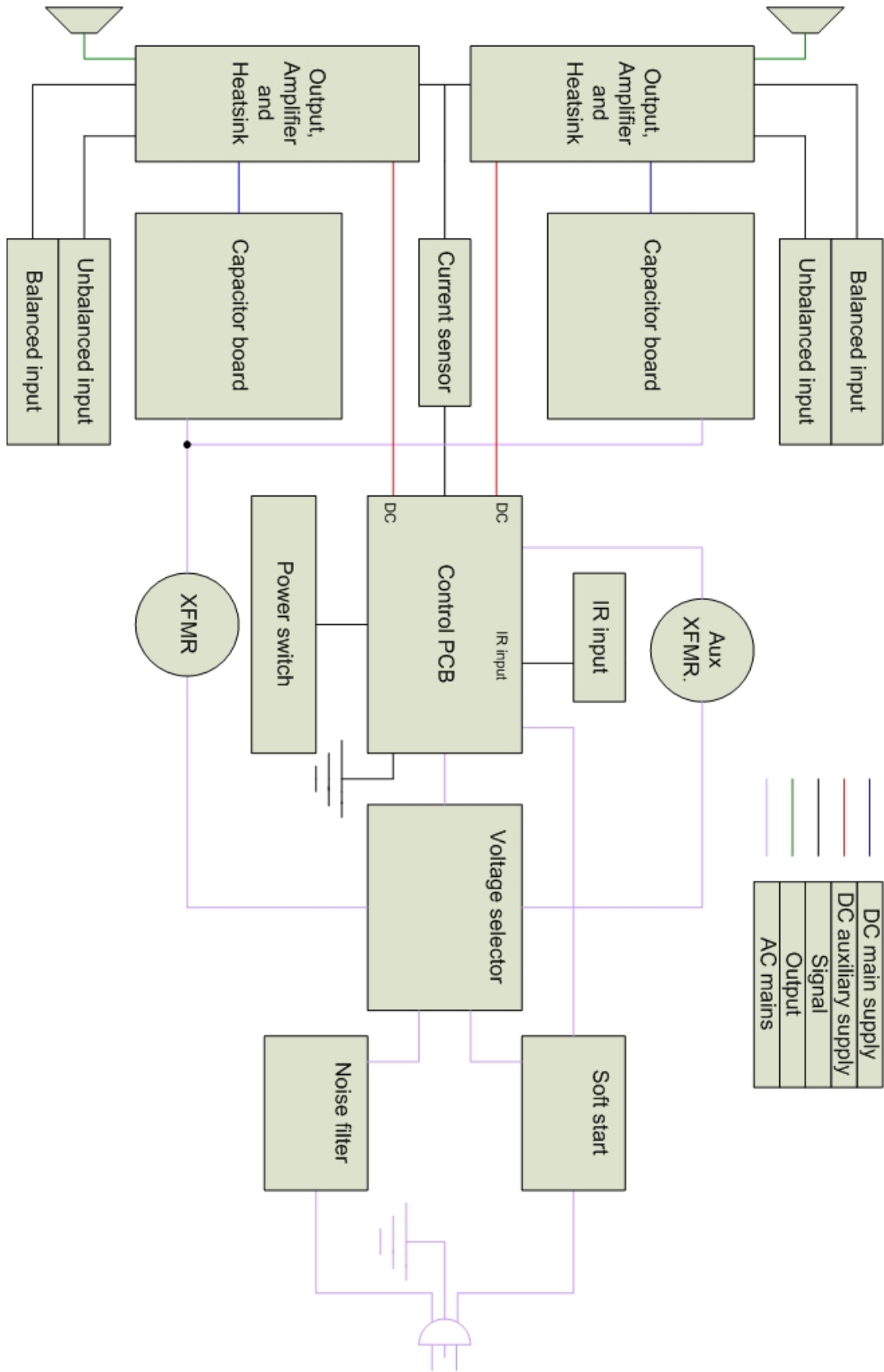

# Start Up Procedure

When receiving a unit, an assiduous visual inspection must be performed. Do not connect the unit without analysing the symptoms reported by the customer and the results of the inspection.

Using the troubleshooting guide, find the problem and proceed to the repair. Once this step is done, follow these steps, known as the start-up procedure, to ensure that everything in the unit is in working condition.

1. Proceed with a post repair visual inspection. Take the time to check if every wire is reconnected properly, every screw is bolted on, no soldering and/or metal residues lying in the unit, every fuse has been replaced, etc.
2. Connect the unit to a variable transformer, setted to 0Vac.
3. Turn the bias trimpot (RV1) counter clockwise until a click is heard.
4. Connect the bypass wire to the variable transformer. This bypass is a power cord, modified on the female side in order to bypass the soft start sequence. It is connected to the line tab on soft start PCB.
5. Slowly raise the voltage to 10Vac, and check positive and negative rails. Check fuses.
6. If one or more supply are not within specifications, return to the troubleshooting guide.
7. Slowly raise voltage until you hear relays click, this point is around 55Vac. Recheck every supply.
8. If one or more supply are not within specifications, return to the troubleshooting guide.
9. Raise voltage to 120Vac. Recheck every supply
10. If every supply is within specifications, unplug the unit and bypass from the variable transformer. Reconnect only the unit.
11. Report to calibration and adjustments to adjust bias and DC offset. Note that bias can be adjusted to 10mV, and the following tests can be performed before the unit is send to the burn-in bench for a 24 hours warm-up.
12. Connect the unit to a load, and to a source using balanced inputs and single ended inputs, independently.
13. Perform a test with a 200Hz, a 2kHz and a 20kHz tone, both sinus wave and square wave. Check the output with a oscilloscope, on 4 ohms and 8 ohms loads. Take special cares about oscillation and phase correlation between channels.
14. Connect the unit to a small speaker, and short the input. Check for any noise. Perform this step with single ended inputs and balanced inputs, independently.
15. Put the unit on a burn-in bench, and let it sit for 24 hours, then readjust bias. Let the unit on the burn-in bench for another 72 hours.
16. Redo steps 11 to 14 before shipping to the customer.

## Protection Modes and Indicators

The front LED shows the status of the amplifier. When starting up normally, the CAV180 will show a FLASHING RED LED for about 15 seconds and if all is normal, the LED will go SOLID RED. If there is a fault, the LED will go to a FLASHING GREEN LED. The CAV180 is not equipped with any protection fuses. In the event that the protection is triggered, the technician will first need to identify and cure the cause of failure (please report to troubleshooting guide). When the cause has been identified, disconnect the unit from the system including the AC power. Remove the top cover and look for damaged or burned components.

# Troubleshooting Guide

Symptom	Possible cause
Unit won't turn on	Check connections; Check fuses; Check soft-start circuit; Check relays; Check power supply circuits (positive rail, negative rail)
Smoked and/or burned components	Check for short between components and ground; Check output transistors; Check power supply circuits (positive rail, negative rail).
Blown fuses	Check for short between fuse and ground; Check power supply circuits (positive rail, negative rail).
No output	Check connexions; Check output relays; Check power supply circuits (positive rail, negative rail,); Check output transistors.
Unit turn into protection	Check for smoked and/or burned components; Check power supply circuits (positive rail, negative rail,); Check source and load; Check protection circuit; Check sensor wires between sensor PCB and control PCB; Check outputs transistors and Mosfet drivers; Perform updates, if necessary.
Excessive buzz and/or hum	Check electrical lines; Check for a ground loop in the system.
Oscillation	Check source; Check capacitors on main board; Check 4.7Ω resistor.
Intermittent signal	Check connections; Replace shield wires.

# Output Transistors Testing and Replacement



**PLEASE NOTE THAT THESE TESTS ARE ONLY EFFECTIVE ON BIPOLAR TRANSISTORS. DO NOT PERFORM THESE TESTS ON MOSFET DEVICES, AS THEY ARE LIKELY TO BECOME SHORT DURING THE TEST.**

You should check all pin combinations, as there is a chance that only one side of the transistor is short. When replacing outputs transistors, the technician should first disconnect both outputs and main board to check if the blown outputs were caused by a faulty component on the amplifier's base. Blown output transistors should be replaced by kits, not individually. These kits contains matched transistors for both rails of one channel. When replacing blown output transistors, you must also replace positive and negative Mosfet drivers and bias transistor. Carefully inspect 4.7Ω resistor and 10Ω soft start resistor, and replace if necessary. Replace any burnt component or board.

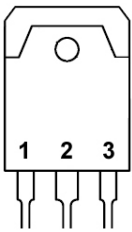

Pins : 1      Base  
          2      Collector  
          3      Emitter

You should have these results, if the transistor is good.

2SC3263 (NPN)

Positive lead	Negative lead	Result
B	C	Conductive
B	E	Conductive
C	B	Infinite
C	E	Infinite
E	B	Infinite
E	C	Infinite

2SA1294 (PNP)

Positive lead	Negative lead	Result
B	C	Infinite
B	E	Infinite
C	B	Conductive
C	E	Infinite
E	B	Conductive
E	C	Infinite



# Calibrations and Adjustments

## Bias adjustment:

Note: Bias adjustment should be made without any load connected to the amplifier's output, and no signal connected to the amplifier's input.

1. Connect a multimeter to R5 leads and set the multimeter to mV scale.
2. Turn trimpot RV1 counterclockwise until it reaches  $0\Omega$ . A click should be heard.
3. Turn on amplifier, and let it warm up for 15 minutes on idle.
4. Adjust trimpot RV1 to get a 10mV reading.
5. Let the amplifier warm up for a 24 hours period with signal and load.
6. Remove signal and load, and reconnect the multimeter, setted to mV scale, to R5 leads. Note the reading, and readjust if necessary.

## DC offset:

Note: DC offset adjustment should be made without any load connected to the amplifier's output, and no signal connected to the amplifier's input.

On these units, DC offset can't be adjusted. Measure DC offset using a voltmeter connected to the output posts, scale setted to mV. DC offset should be less than 10mV.

# Parts List

This is not a detailed part list. It is a list of major chassis parts and PCBs. If you need to order a specific part, please contact Classe Audio with the part location, PCB number, and model and serial number of the unit. If you need a complete PCB, please replace the (x) in the Classe part number with the revision number printed on the board.

Parts	Description	Classe part number
B1D9X	Complete PCB, negative sensor	B1D9XR(x)
B1DBX	Complete PCB, positive sensor	B1DBXR(x)
B02AX	Complete PCB, amplifier	B02AXR(x)
B2E1X	Complete PCB, capacitors	B2E1XR(x)
B2E2X	Complete PCB, heatsink	B2E2XR(x)
B2E3X	Complete PCB, speaker terminal	B2E3XR(x)
B2E4X	Complete PCB, soft start	B2E4XR(x)
B2E5X	Complete PCB, input	B2E5XR(x)
B2E7X	Complete PCB, control	B2E7XR(x)
B2E8X	Complete PCB, IR sensor	B2E8XR(x)
B1DAX	Complete PCB, switch	B1DAXR(x)

# Updates

1. On board B2E2X, replace R1 with Classe part number 3299X-1-202 (5 PCBs).
2. On board B02AX, replace R113 and R103 with following assembly. Use Classe part number A307-1078. Connect the resistor assembly to the exterior pads of R113 and R103.



**4x RN60D1002 (10k, 1/2 watt)**

3. On board B2E7X, disconnect the ground wire and connect it to position GND7 on B2E3X PCB.
4. On board B2E2X (5 PCBs), make sure that Q1 and Q2 are part number 2SK79 and 2SK216. They should be mounted on a small aluminium block, which is mounted to the chassis (see following pics). If they are printed as ECX10N20 and ECX10P20, replace them, using the following guide.

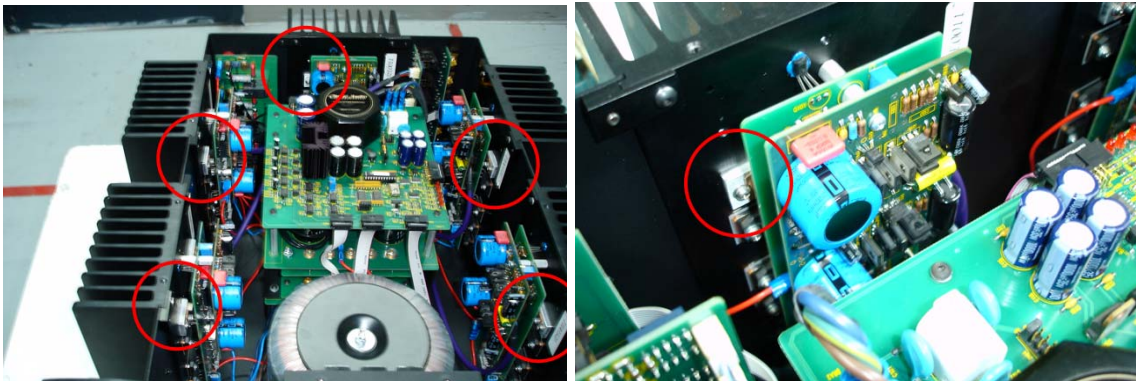

Parts needed: G213-1029, Mosfet, x5; G213-1031, Mosfet, x5; G307-1078, Silpad, x10; 385-288, Screw, x10; A306-1048, Lock washer, x10; MS-15795-803, Washer, x20; A306-1020, Shoulder washer, x10; L252XR00, aluminium spacer, x10

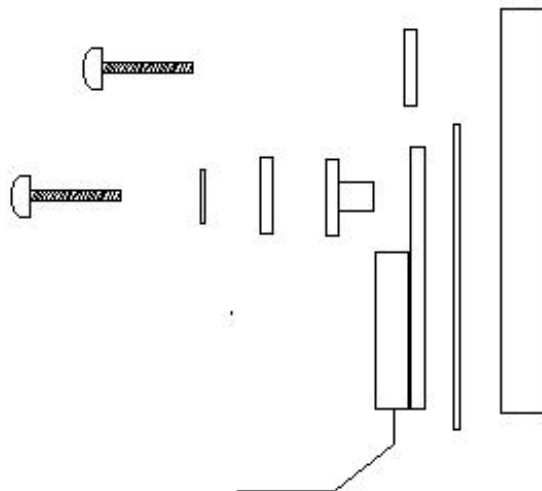

# Fuses



EXTRA PRECAUTIONS SHOULD BE TAKEN WHEN REPAIRING, MODIFYING, OR TROUBLESHOOTING IN THE POWER SUPPLY AREA. UNIT MUST BE DISCONNECT FROM MAIN SOURCE AND CAPACITORS MUST BE DISCHARGED USING A 100W INCANDESCENT BULB.



WHEN REPLACING FUSES, PLEASE MAKE SURE THAT THE FUSE HOLDERS ARE HOLDING THE FUSES VERY TIGHTLY. A LOOSE FUSE HOLDER CAN TRANSLATE INTO DISTORTION ON TOP OF THE SIGNAL.

Main fuses:

For 100 – 120v units: 10A slo-blo, Classe part number MDA-10A

For 220 – 240v units: 8A slo-blo, Classe part number MDL-8A

The main fuse is located at the back of the unit, on the rear panel.

Control board fuse: 0.50A, Classe part number 225.500

The control board fuse is located on top of the control board (B2E7X)

# Voltage Change



EXTRA PRECAUTIONS SHOULD BE TAKEN WHEN REPAIRING, MODIFYING, OR TROUBLESHOOTING IN THE POWER SUPPLY AREA. UNIT MUST BE DISCONNECT FROM MAIN SOURCE AND CAPACITORS MUST BE DISCHARGED USING A 100W INCANDESCENT BULB.

1. Set the primary wires of the main transformer as described below.
2. Replace the varistor, according to new line voltage, following Classe’s recommendations. If varistor is not available, remove old varistor and leave it empty.
3. Set the jumpers accordingly on the auxiliary transformer located at the back of the unit on the top main board on the left-hand side of the auxiliary transformer (see tables below)

Primary wires, main transformer

Mains	N1	N2	X1	X2	X3	X4	X7	X8	Varistor
100VAC	White	Orange	Gray	Yellow	Blue	Black	-	-	140
120VAC	White	Orange	Blue	Black	Gray	Yellow	-	-	140
220VAC	White	-	-	Yellow	Gray	Black	Blue	Orange	250
240VAC	White	-	-	Black	Gray	Yellow	Blue	Orange	250

Jumpers, auxiliary transformer

Mains	Position 1	Position 2	Position 3	Position 4	Position 5
100/120VAC	In	Out	Out	Out	In
220/240VAC	Out	Out	In	Out	Out

# IR Interface Information

Press and hold:

AMP	+	LINE 1 =	Turns on Amplifier # 1
AMP	+	LINE 2 =	Turns on Amplifier # 2
AMP	+	LINE 3 =	Turns on Amplifier # 3
AMP	+	BAL 1 =	Turns on Amplifier # 4
AMP	+	BAL 2 =	Turns on Amplifier # 5
AMP	+	BAL 3 =	Turns on Amplifier # 6

J3	J2	J1	J0	ADDRESS	RC Button	Auto ON	Note
X	X	X	X	0	Amp1	No	QC setting
X	X	X	Out	1	Amp2	No	
X	X	Out	X	2	Amp3	No	
X	X	Out	Out	3	Amp4	No	
X	Out	X	X	4	Amp5	No	
X	Out	X	Out	5	Amp6	No	
X	Out	Out	X	0	Amp1	No	
X	Out	Out	Out	0	Amp1	Yes	On with AC
Out	X	X	X	0	DC	No	
Out	X	X	Out	1	DC	No	
Out	X	Out	X	2	DC	No	
Out	X	Out	Out	3	DC	No	
Out	Out	X	X	4	DC	No	
Out	Out	X	Out	5	DC	No	
Out	Out	Out	X	0	DC	No	
Out	Out	Out	Out	0	DC	Yes	On with AC



6 5 4 3 2 1

REVISION RECORD			
LTR	ECO NO:	APPROVED:	DATE:

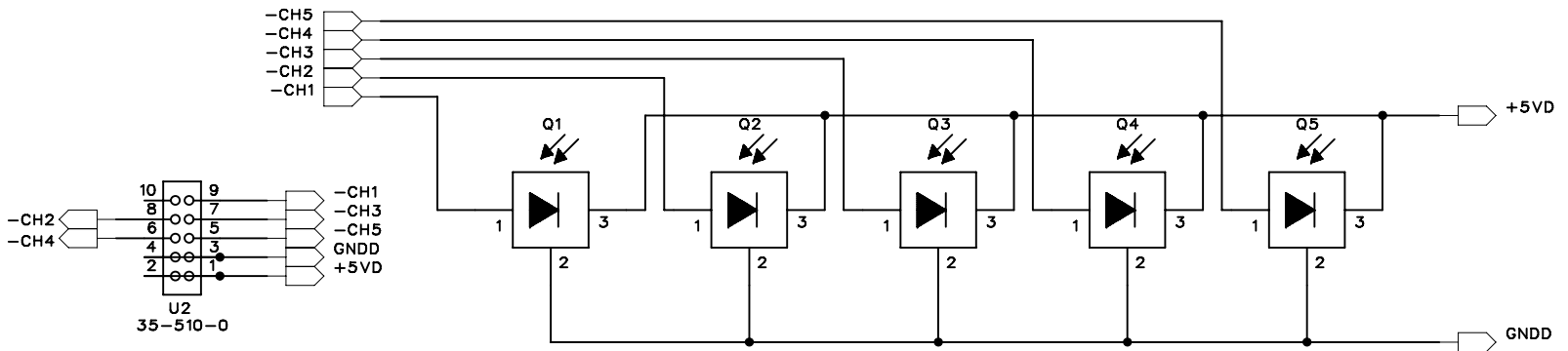

COMPANY: CLASSE AUDIO INC.			
TITLE: CAV 180 Negative_Sensor			
CODE:	SIZE:	DRAWING NO: B1D9XR02	REV:
SCALE: JUNE 30, 2000		SHEET: OF	

DRAWN:	DATED:
CHECKED:	DATED:
QUALITY CONTROL:	DATED:
RELEASED:	DATED:

D  
C  
B  
A

D  
C  
B  
A

6

5

4

3

2

1

D

D

C

C

B

B

A

A

REVISION RECORD			
LTR	ECO NO:	APPROVED:	DATE:

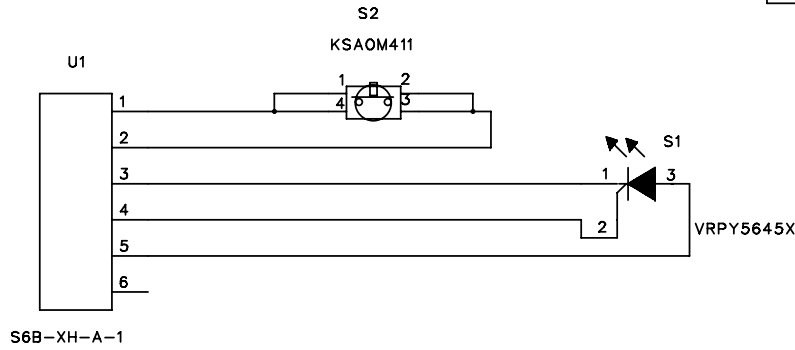

COMPANY:			
TITLE: <h1>POWER SWITCH</h1>			
CODE:	SIZE:	DRAWING NO: <h2>B1DAXR01_CA301</h2>	REV:
SCALE:		JUNE 27, 2000	SHEET: 1 OF 1

DRAWN:	DATED:
CHECKED:	DATED:
QUALITY CONTROL:	DATED:
RELEASED:	DATED:



6 5 4 3 2 1

REVISION RECORD			
LTR	ECO NO:	APPROVED:	DATE:

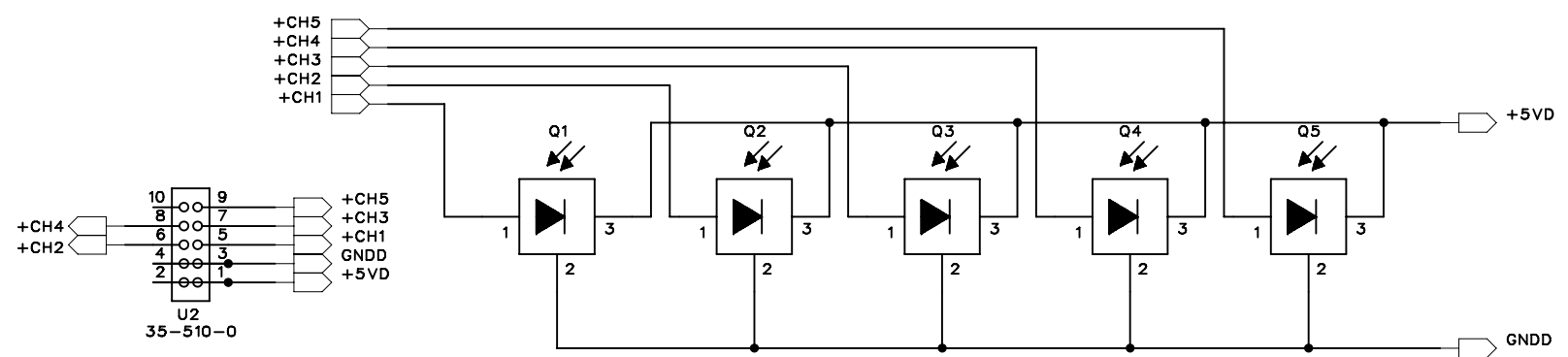

COMPANY: CLASSE AUDIO INC.			
TITLE: CAV 180 Positive_Sensor			
CODE:	SIZE:	DRAWING NO: <b>B1DBXR02</b>	REV:
SCALE: JUNE 30, 2000		SHEET: OF	

DRAWN:	DATED:
CHECKED:	DATED:
QUALITY CONTROL:	DATED:
RELEASED:	DATED:

D

D

C

C

B

B

A

A

6

5

4

3

2

1

REVISION RECORD			
LTR	ECO NO:	APPROVED:	DATE:

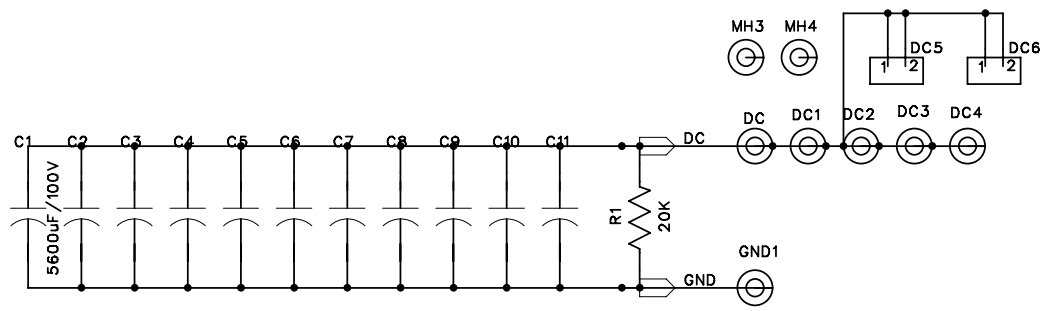
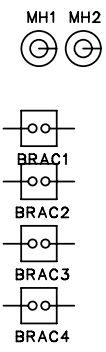

USE CLASSE LIBRARY

COMPANY: CLASSE AUDIO INC.

TITLE: CAV180 CAP PCB

This PCB is used for Pos, for the Neg all the CAP are reversed.

DRAWN:	DATED: NOV/23/00
CHECKED:	DATED:
QUALITY CONTROL:	DATED:
RELEASED:	DATED:

CODE:	SIZE:	DRAWING NO:	REV:
		B2E1XR00	

SCALE: SHEET: 1 OF 1

D

D

C

C

B

B

A

A

6                      5                      4                      3                      2                      1

REVISION RECORD			
LTR	ECO NO:	APPROVED:	DATE:

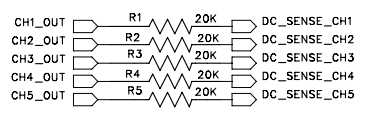
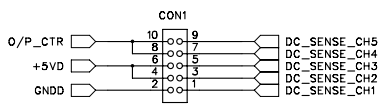
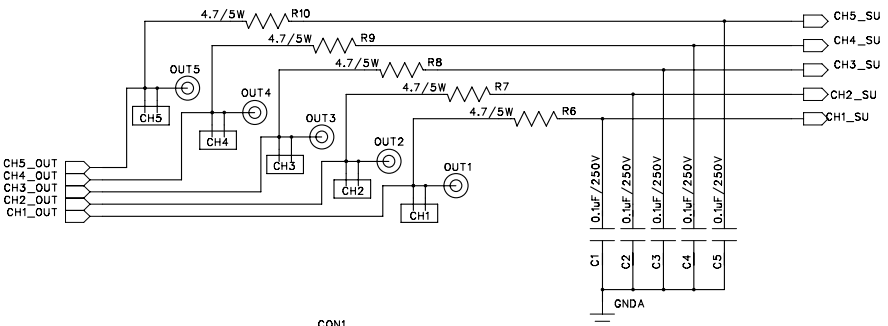
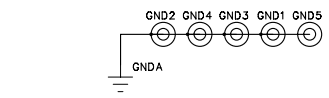
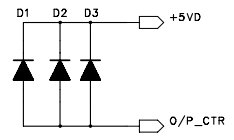
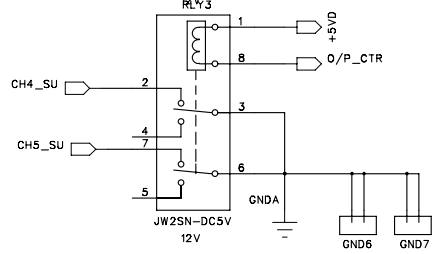
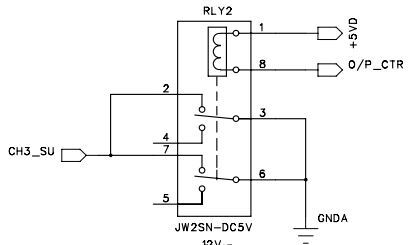
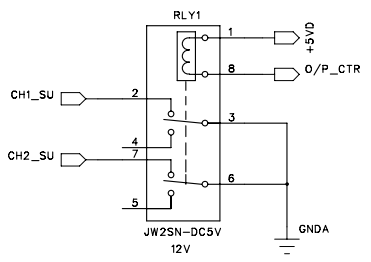

DRAWN:	DATED:
CHECKED:	DATED:
QUALITY CONTROL:	DATED:
RELEASED:	DATED:

COMPANY: <b>Classé Audio Inc.</b>			
TITLE: <b>CAV180 SPEAKER TERMINAL PCB</b>			
CODE:	SIZE:	DRAWING NO: <b>B2E3XR00</b>	REV:
SCALE:		SHEET:    OF	

D

C

B

A

D

C

B

A

6                      5                      4                      3                      2                      1

REVISION RECORD			
LTR	ECO NO:	APPROVED:	DATE:

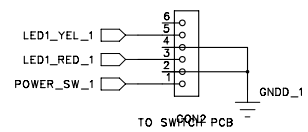
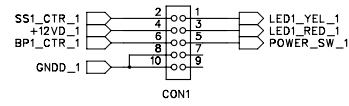
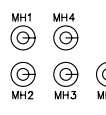
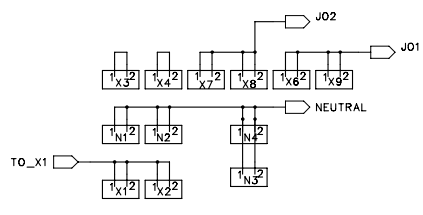
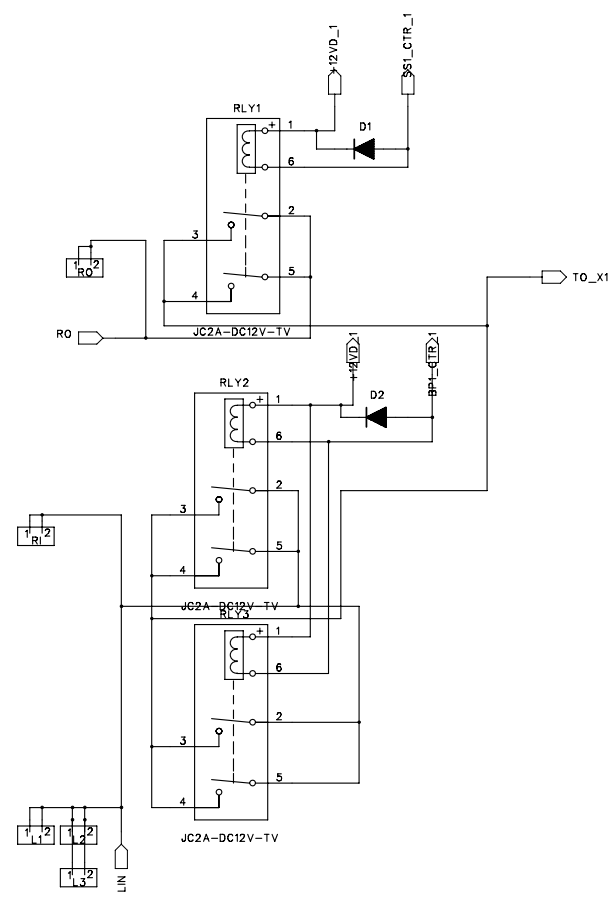

D  
C  
B  
A

D  
C  
B  
A

COMPANY: <b>CLASSE AUDIO INC.</b>			
TITLE: <b>CAV180 BP/SS/VB PCB</b>			
CODE:	SIZE:	DRAWING NO: <b>B2E4XR00</b>	REV:
SCALE:		SHEET: 1 OF 1	

DRAWN:	DATED:
CHECKED:	DATED:
QUALITY CONTROL:	DATED:
RELEASED:	DATED:

6

5

4

3

2

1

REVISION RECORD			
LTR	ECD NO:	APPROVED:	DATE:

D

C

B

A

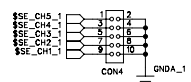
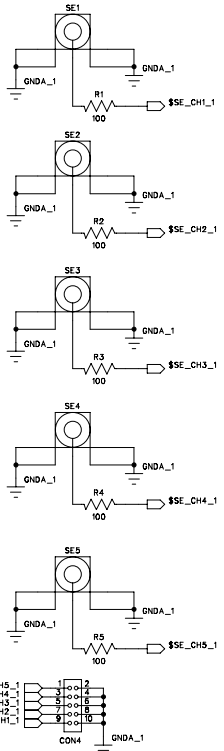

MH1

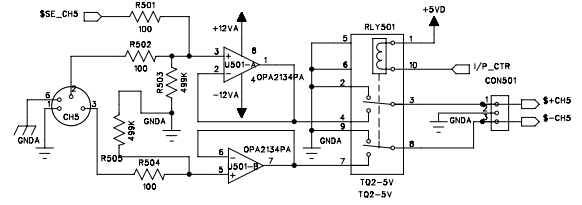
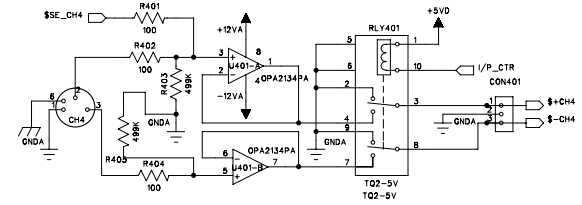
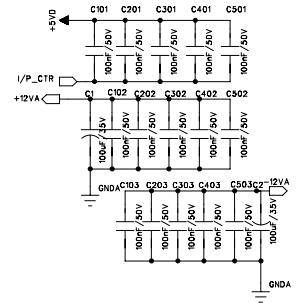
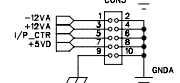
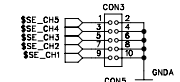
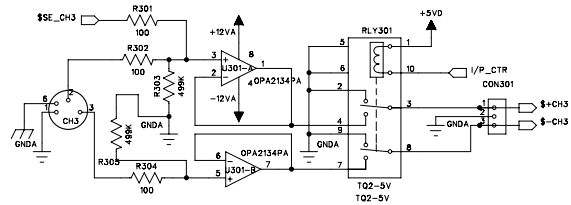
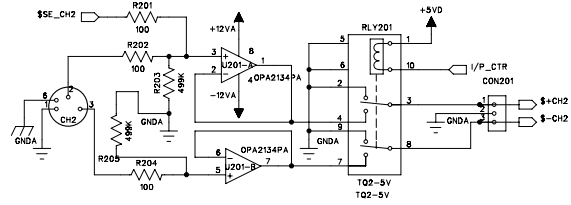
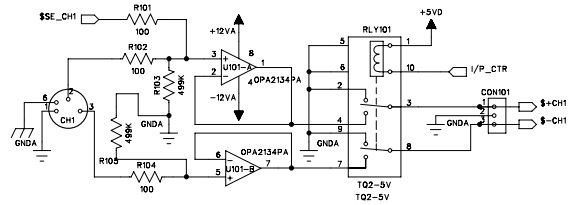

COMPANY:				CLASSE AUDIO INC.			
TITLE:				CAV180 INPUT PCB			
DRAWN:	DATED:	CODE:	SIZE:	DRAWING NO:	REV:		
CHECKED:	DATED:			B2E5XR00			
QUALITY CONTROL:	DATED:						
RELEASED:	DATED:						
SCALE:				SHEET: 1 OF 1			

D

C

B

A

6

5

4

3

2

1

REVISION RECORD			
LTR	ECO NO:	APPROVED:	DATE:

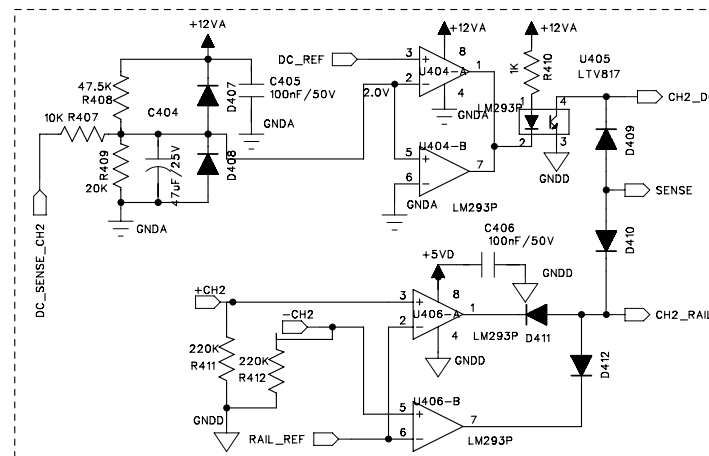
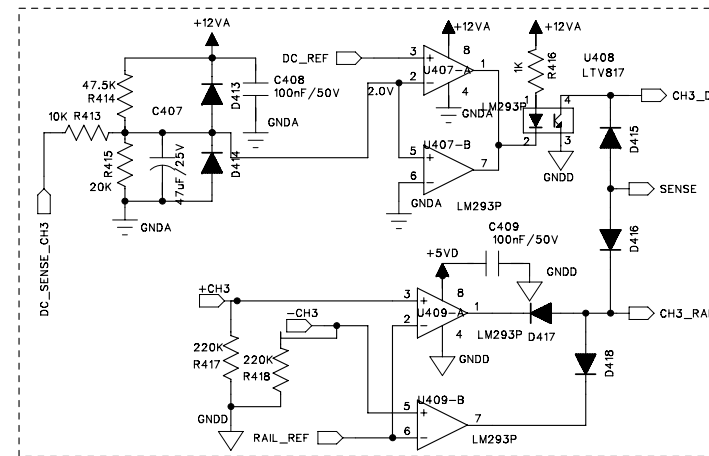
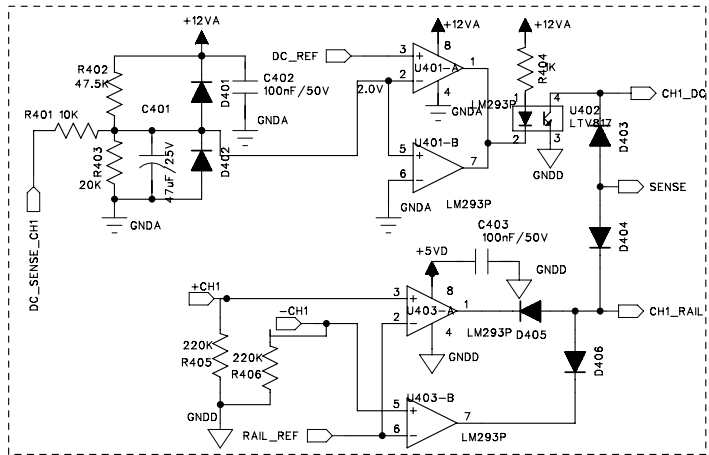

COMPANY:				<b>CLASSE AUDIO INC.</b>			
TITLE:				<b>CAV180 SENSORS CH1/3</b>			
CODE:		SIZE:		DRAWING NO:		REV:	
				<b>B2E7XR00</b>			
SCALE:				SHEET: 4 OF 5			

DRAWN:	DATED:
CHECKED:	DATED:
QUALITY CONTROL:	DATED:
RELEASED:	DATED:

D

C

B

A

D

C

B

A

6

5

4

3

2

1

D

C

B

A

D

C

B

A

REVISION RECORD			
LTR	ECO NO:	APPROVED:	DATE:

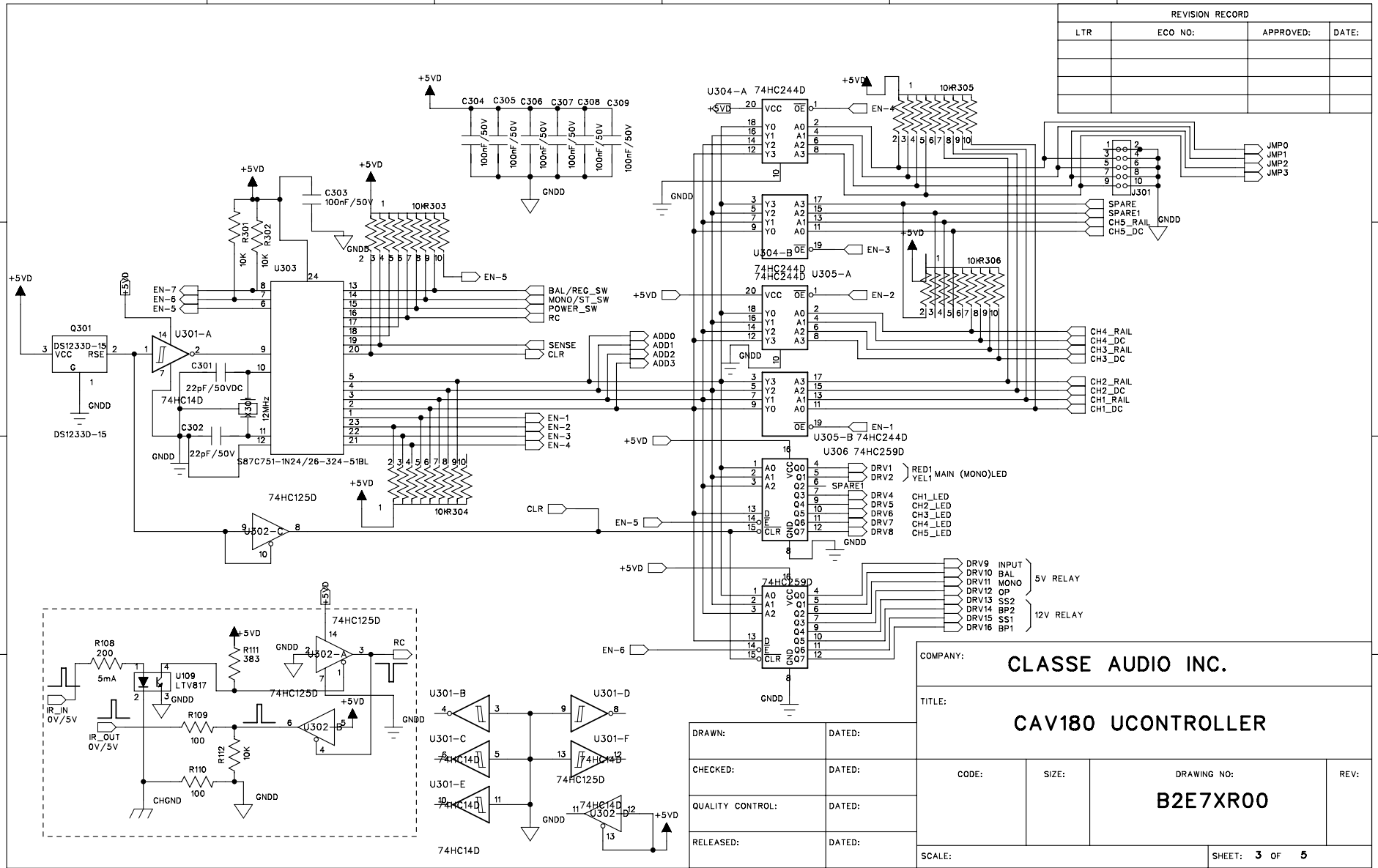

COMPANY: <b>CLASSE AUDIO INC.</b>			
TITLE: <b>CAV180 UCONTROLLER</b>			
DRAWN:	DATED:	CODE:	REV:
CHECKED:	DATED:	SIZE:	DRAWING NO: <b>B2E7XR00</b>
QUALITY CONTROL:	DATED:	SCALE:	SHEET: <b>3 OF 5</b>
RELEASED:	DATED:		

6

5

4

3

2

1

D

C

B

A

D

C

B

A

REVISION RECORD			
LTR	ECO NO:	APPROVED:	DATE:

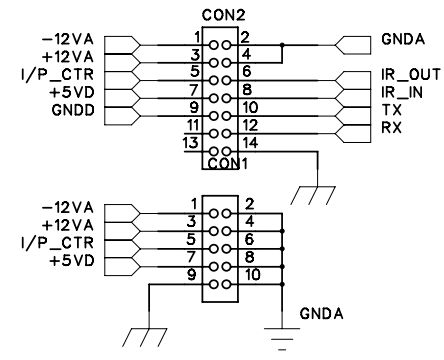
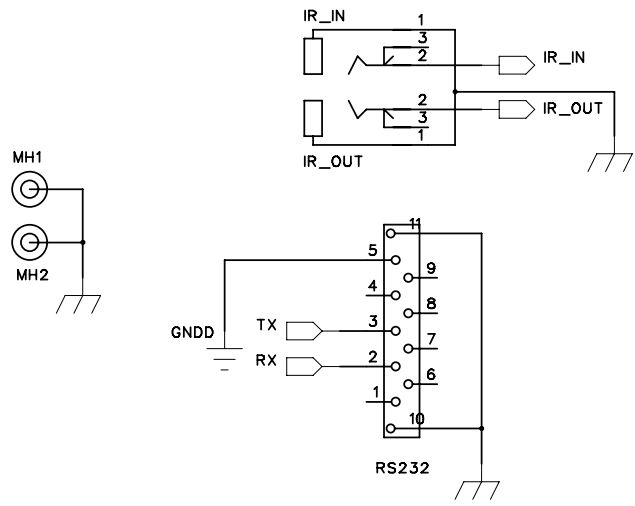

USE CLASSE LIBRARY

COMPANY: CLASSE AUDIO INC.

TITLE: CAV180 IR PCB

DRAWN:	DATED: FEB 27, 2001
CHECKED:	DATED:
QUALITY CONTROL:	DATED:
RELEASED:	DATED:

CODE:	SIZE:	DRAWING NO:  B2E8XR00	REV:
-------	-------	-----------------------------	------

SCALE: SHEET: 1 OF 1